

Chapter 18

Audio Outputs

Audio Configurations

The K2500 features ten audio jacks, enabling you to route the K2500's sounds through its own internal effects processor, through an external effects device, or through combinations of the two. Of course the K2500's effects processor can be bypassed as well.

On the rear panel are a pair of stereo mix jacks (MIX L and R), and eight additional jacks—A (L and R), B (L and R), C (L and R), and D (L and R). These can be configured as four stereo pairs or as eight separate outputs. Your audio configuration is determined by two factors. The “hardware” side has to do with which jacks you use and what kind of cables you connect to them. The “software” side depends on the settings you make for parameters on the OUTPUT page in the Program Editor, and on the Master mode page.

The simplest configuration would involve connecting the left and right MIX outputs directly to a mixing board or keyboard amplifier. If you're using only one input to your sound system from the K2500, use the left MIX output for a mono signal. We'll assume for now that you're using only the MIX outputs. The use of the separate outputs is discussed later in this chapter.

Note: we recommend that you make the cable connection to the K2500 (or any instrument) after you've made your other audio connections, since this reduces the chance of creating static electricity that can cause an audible “pop” (and, in extreme cases, cause equipment damage).

Using the MIX Outputs

If you plan to use the K2500's global effects processor to add dimension to your sounds, you'll need to use the MIX outputs. The audio output to the separate outputs is always dry—that is, the audio signal is sent to the separate outputs without passing through the global effects processor. The MIX outputs and the headphone jack are the only jacks where the signal will appear with effects.

The signal is routed using the OUTPUT page in the Program Editor. While in Program mode, press the EDIT button, then press one of the <more> soft buttons until you see “OUTPUT” on the display's bottom line. Press the corresponding soft button, and the OUTPUT page will appear. Set the value of the Pair parameter to A(FX) if you want the current layer's sound to be routed through the effects processor before appearing at the MIX outputs.

A value of A(FX) means two things: first, the layer's sound will appear with effects at the MIX outputs, and second, that the layer's sound will appear *without* effects at the Group A outputs if standard audio cables are inserted into the Group A output jacks. Set the value of the Pair parameter to B(DRY), C(DRY), or D(DRY) if you want the layer's sound to appear without effects at the MIX outputs. It will also appear at the Group B, C, or D outputs if standard audio cables are inserted into the respective output jacks. Connecting audio cables to the separate outputs will remove part or all of the signal from the MIX outputs. Be sure to set the output pair for every layer in the program; each layer can be routed independently (use the CHAN/Bank buttons to scroll through the layers). You'll also want to set the pan position for each layer while you're on the OUTPUT page. Depending on the program you're working with, you'll have several different options for panning. See “The OUTPUT Page” in Chapter 6 for an explanation of these options. Also see “PANNER” in Chapter 14 to learn how to gain even more control over a layer's pan position.

Using the Separate Outputs

The K2500's eight separate outputs are arranged in four pairs, A, B, C, and D. These are mono output jacks, and you'll normally plug a standard audio cable into one or more of them. Depending on the OUTPUT page settings you use for a given program's layers, they can function as four stereo output pairs, or as eight separate outputs.

The diagram below illustrates the wiring of the K2500's audio system. From the sound engine, the audio signal can be routed to any of the four output groups. If the signal is routed to Output Group B, C, or D it will appear at the MIX outputs if no audio cables are plugged into those outputs. Plugging cables into any of the separate outputs will divert the signal from the MIX outputs to that output.

If the signal is routed to Output Group A, and audio cables are plugged into the A outputs, the signal will pass directly to the A outputs. If no cables are plugged into the A outputs, the signal will pass from the sound engine to the global effects processor. The left and right sides are mixed before passing to the effects processor. The effects processor splits the signal into left and right sides again after the effects are applied. Effects will be applied to both sides of the signal unless the Out A->FX parameter is set to L Only, in which case only the left side will have effects applied. In either case, the signal will pass to the MIX outputs. Remember that the effects processor isn't stereo; effects can't be panned the way dry sounds can.

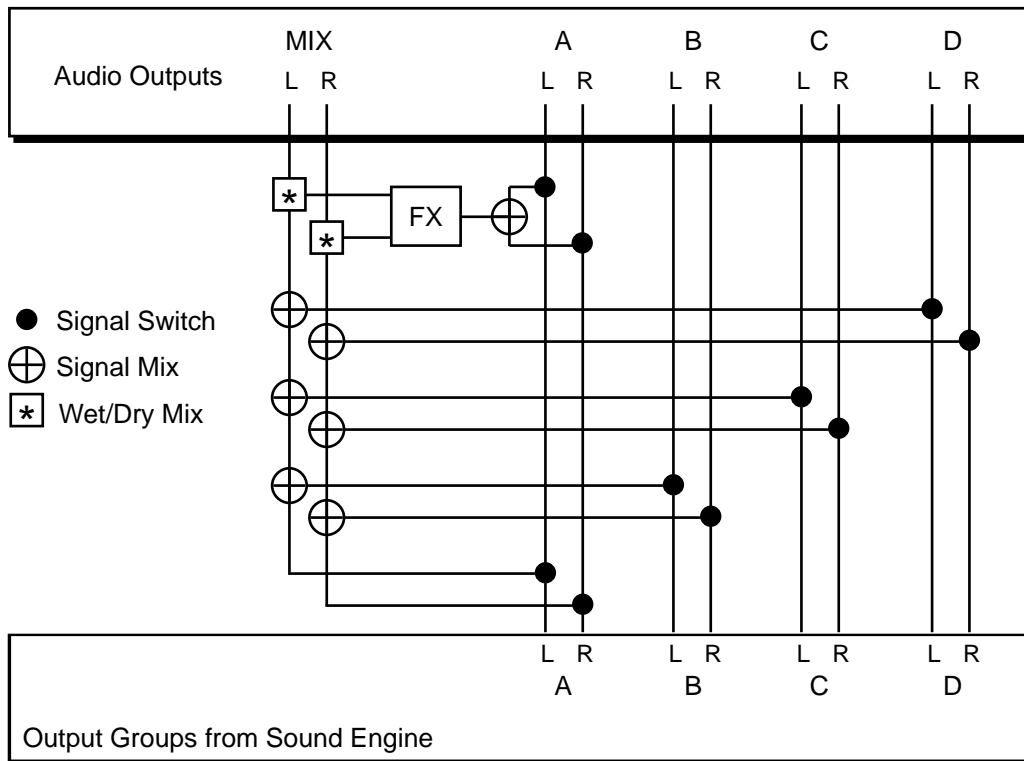

If a layer's pan position is centered, then the outputs to which it's assigned will carry an equal mix of the layer's sound in its left and right outputs. This makes the audio outputs a stereo pair with respect to that layer. If the layer is panned all the way to the left or right, the separate outputs function as individual monophonic outputs with respect to that layer. Of course, you could have a multi-layer program with all its layers assigned to the same output group, and pan each layer so that some of them appear at both outputs, while others appear only at the left or right output. If you're using your K2500 for recording and multi-timbral sequencing, you'll want to use the separate outputs to increase your mixdown options, and for adding outboard effects to your sounds. The separate outputs give you a great deal of added flexibility.

Hardware Audio Switching

It's important that you understand the effect on the MIX outputs when you use the separate outputs. When you connect a standard audio cable to any of the separate outputs, *every* sound (or part of a sound) that's assigned to the output you connect will be removed from the MIX outputs. For example, imagine that you plug a cable into the left output of Group A. The left side of every program layer assigned to Output Group A will disappear from the left side of the MIX outputs, and will appear only at the left Group A output. If a layer is panned all the way left, it will disappear from the MIX outputs entirely. If it's centered, the left side will disappear, but the right side will remain at the right MIX output. A layer that's panned hard right will not be affected in this case. If you use all eight separate outputs, the MIX outputs will not carry any signal.

The pan settings you make on each program's OUTPUT page apply to the separate outputs just as they do for the MIX outputs. Keep in mind, however, that the signal at the separate outputs will always be dry; only the MIX outputs make use of the global effects processor.

Once you have the output groups assigned on the OUTPUT page, you can go to Master mode to specify how the signal will appear at the MIX outputs. On the Master mode page are three parameters that affect the routing of all signals that are sent to the MIX outputs. The settings for these parameters will affect each layer in every program.

The parameters Out A->Mix and Out B->Mix determine the panning of the A and B Group's audio signal at the mixed outs. If they're set to Stereo, then whatever panning is applied to each program (as set on the OUTPUT page in the Program Editor) will show up at the MIX outputs. Output groups C and D are permanently set to Stereo.

If either of these parameters is set to Mono, then programs routed to the corresponding audio output group will send all of their sound at equal levels to both outputs, regardless of any panning that might be applied to them on the OUTPUT page. This is a quick and convenient way to convert the MIX outputs into two mono outputs.

The parameter Out A->FX is intended for special cases when you want an additional separate output that doesn't go through the K2500's effects processor. A value of L Only bypasses the effects processor for all sounds assigned to the right side of Output Group A. There's an example in Chapter 11 that describes how to use this parameter.

Using Stereo Insert Cables

The preceding description of the separate outputs is only part of the picture. You can make the separate outputs even more useful by using stereo insert cables. A stereo insert cable has a single stereo plug on one end; the other end is split into two mono cables fitted with mono plugs. By plugging the stereo end of a stereo insert cable into one or more of the K2500's separate outputs, you can create all sorts of audio configurations with outboard gear. The tip of the stereo end carries the signal to the send side of the split end, and the ring of the stereo end receives the signal from the return side.

Effects Return

Plug the stereo end of a stereo insert cable into one of the K2500's separate outputs, then plug the send (tip) side of the split end into an input on an outboard effects box. If you connect the effects box's output to the return (ring) side of the split end, you've created a loop that will send the K2500's output into the effects box, and return it wet to the K2500. Since the loop returns the signal to the same output jack on the K2500, the K2500's MIX outputs act as if there were no cable at all plugged into the separate output, and the signal will appear at one or both of the MIX outputs. If you're using one of the Group A outputs, you can apply the effect of both the outboard box and the K2500's global effects processor to the corresponding side of the K2500's MIX outputs. If you don't want to double the effects in this way, you can go to Effects mode, set the FX mode parameter to Master, and set the Wet/Dry Mix parameter to 0%. You can also set the Pan parameter of programs routed to Output Group A fully right, then go to Master mode

and set the Out A->Mix parameter to mono, and the Out A->FX parameter to L Only. This will send programs routed to Output Group A to the MIX outputs without going through the K2500's effects processor, but will still send the signal to both the left and right MIX outputs.

INPUT TO K2500

Suppose you want to bring the outputs from a microphone and another synth into the K2500's MIX outputs so you can apply K2500 effects to them. You have two options for setting this up. (You may need to run the mic output through a pre-amp before it gets to the K2500.)

The most versatile way to do this requires an external mixing board. Use standard audio cables to connect the outputs from the other synth and the mic to two of the input channels on the mixing board (for this example, we'll use Channel 1 for the other synth—we'll assume it's a mono unit—and Channel 2 for the mic). Then plug the stereo end of a stereo insert cable into the A Left output of the K2500. Connect the send (tip) side of this cable to Input channel 3 on your mixing board. Connect the return (ring) side of this cable to the left side of a subgroup output on the mixing board. Similarly, connect the stereo end of a second stereo insert cable to the A Right output of the K2500. Connect the send side of this cable to Input channel 4 on the mixing board, and the return side to the right side of the same output subgroup on the mixing board. Pan Channel 3 fully left, and Channel 4 fully right. Pan Channels 1 and 2 as desired.

Here's what happens. Every K2500 sound routed to Output group A will be initially removed from the K2500's MIX outputs, and will pass instead to Channels 3 and 4 on the mixing board. These signals, along with the signals from Channels 1 and 2 on the mixing board (the outputs from the other synth and the mic), will be routed to the mixing board's output subgroup, and will pass to the A outputs of the K2500, which now act as inputs. Since there's a closed circuit between the K2500 and the mixing board, the K2500 handles the input at its A outputs as if it were its own output, and passes it along to the effects processor, then to the MIX outputs. The signals from the other synth and the mic, as well as the K2500's Output group A sounds, will have effects applied to them before they appear at the MIX outputs. (The dry portions of all these sounds will be panned according to your pan settings for Channels 1–4 on the mixing board and the pan settings for the K2500 sounds routed to Output Group A, while the wet portions of all the sounds will appear equally at the MIX outputs.)

A second, simpler method is to pan all the K2500 sounds routed to Output Group A to the left, then connect the output from the other synth or the mic into the K2500's A Right output using a standard audio cable. The K2500 sounds routed to Output Group A will appear at the MIX Left output, and the signal from the other synth or the mic will appear at the MIX Right output. This restricts your panning options somewhat, but is easier to set up.

Output Groups and MIDI Channels

You can also set a program's output group on the basis of the MIDI channel it's assigned to. This is helpful for mixing purposes, in both studio and live situations. When you're using the MIX outputs, it's an easy way to apply or remove effects without editing the program.

To set the output group on the basis of MIDI channel assignments, select MIDI mode by pressing the MIDI mode button. Then press the CHANLS soft button. Use the CHAN/BANK buttons to select the channel you want to edit. The OutPair parameter controls the output group assignment for all programs assigned to the channel. If you choose a value of "Prog" (the default), then any program assigned to that MIDI channel will be routed according to its own output settings on the OUTPUT page in the Program Editor. Otherwise, programs on that channel will be routed according to the settings for the Output Group parameter on the CHANLS page.

Say for example that you set the OutPair parameter for Channel 1 to a value of A(FX). Now when you select MIDI Channel 1 as the current MIDI channel in Program mode, *any* program you select will appear at the A outputs, or at the MIX outputs (with effects) if no cables are connected to the A outputs. Set the OutPair parameter to B(DRY), and any program you assign to Channel 1 will appear at the B outputs, or dry at the MIX outputs if no cables are connected to the B outputs.